

# HIGH PRECISION VERTICAL MACHINING CENTER

High speed High precision High efficiency

DT-50

DT-55

**Taikan**

HIGH-END INTELLIGENT EQUIPMENT TURNKEY SOLUTION SERVICE PROVIDER



High rigidity & High efficiency Vertical machining center

**DT-50/DT-55**

- ★ Extra large base design enables stable cutting for long time
- ★ Quick tool interchange and high-speed cutting enable high productivity

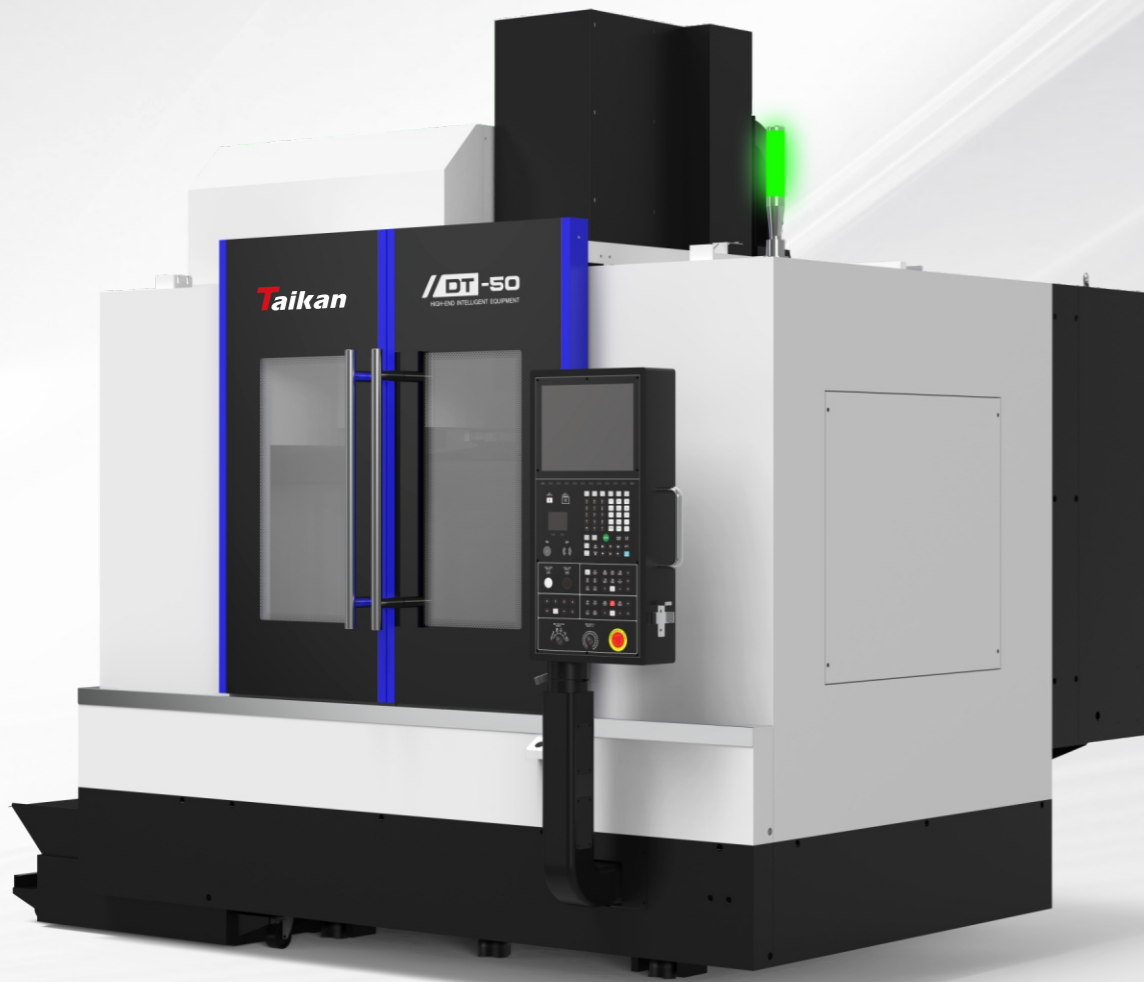

High speed  
High precision  
High efficiency



Workpiece display

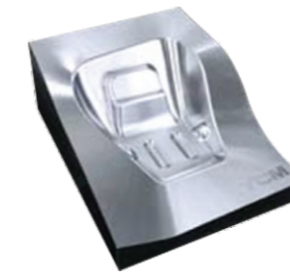
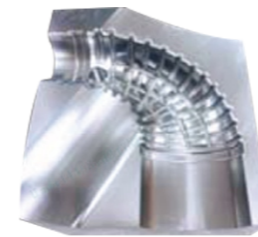

## Vertical machining center

### Technical Description[DT-50/55/]

- ★ Inverted T-type structure design supports the whole process and can achieve stable cutting for a long time.
- ★ The saddle has a double-layer wall panel structure design, long-span support, and excellent dynamic performance.
- ★ The extra large size design of the worktable can provide more processing space; the high-frequency quenching treatment on the workbench surface can improve the hardness and stability of the worktable surface.
- ★ The double-layer wall plate structure design of the spindle box can achieve stable cutting for a long time.
- ★ The double spiral structure design of the base makes chip removal simple and convenient, reducing labor costs and improving production efficiency.

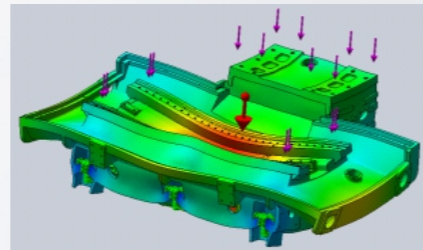
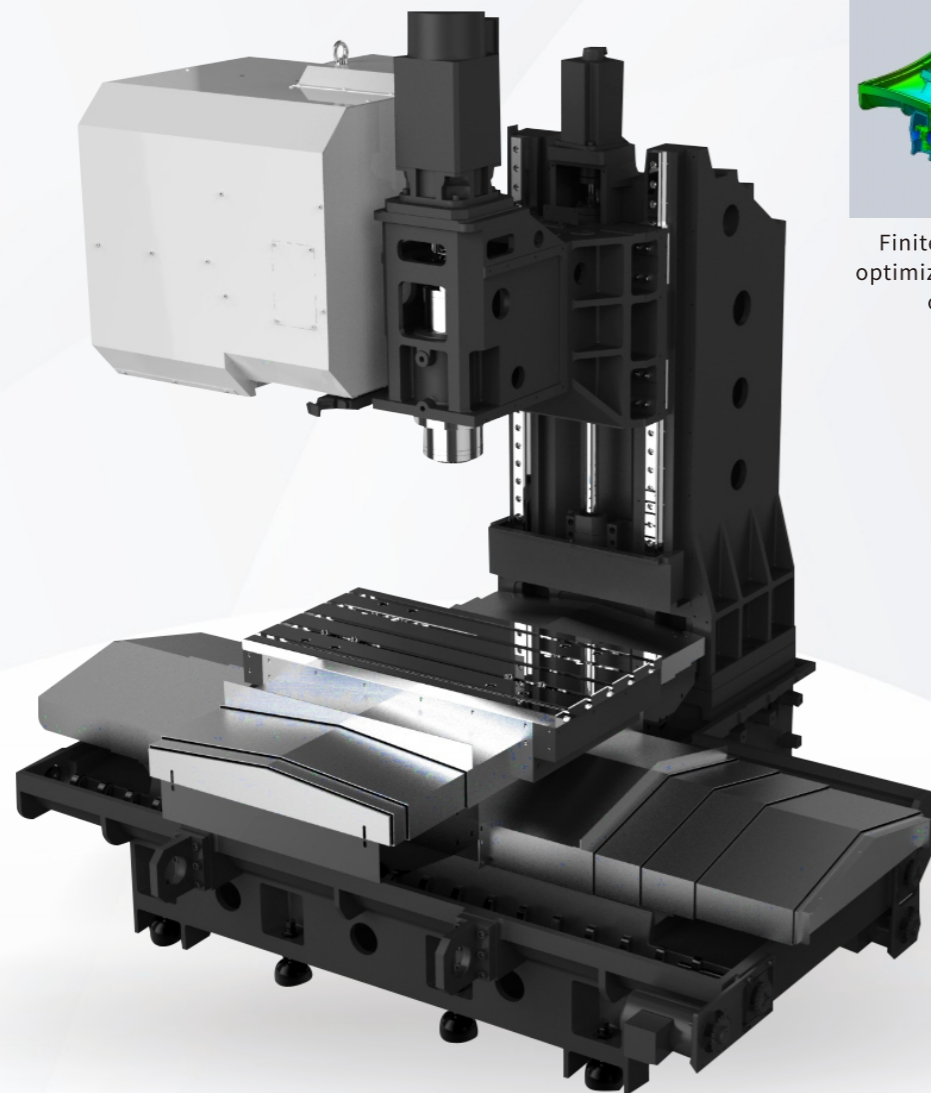

Finite Element Analysis and dynamic optimization are used for simulation to optimize each casting structure.

## Vertical machining center

### Screw hollow cooling

The picture showed thermal imaging data of screw hollow cooling



Screw hollow cooling is a physical cooling technology that transfers the generated heat by delivering a constant-temperature medium to the center of the screw to extend the life of the screw and improve the processing accuracy of machine.

### Screw hollow cooling test results

Comparison of the thermal extension of the screw with and without cooling at a specified operating speed

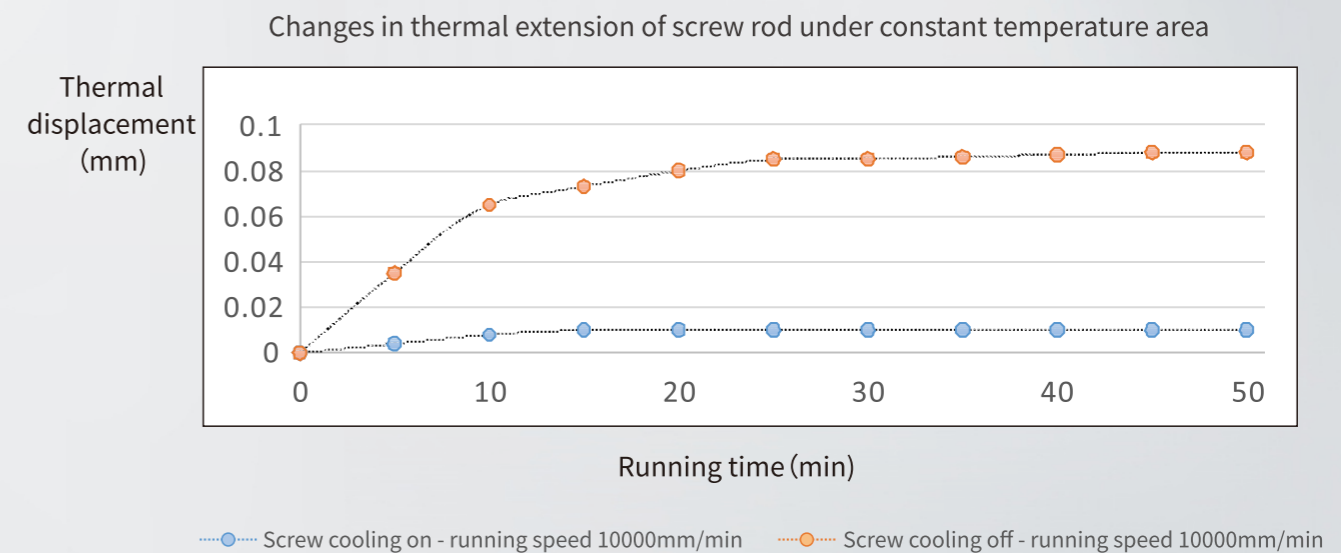

Note: The test data and are not used as machine tool accuracy standards.

### Vertical machining center

High precision & high productivity machining

Spindle output (continuous rating/S6-25%) : 11kW/22kW  
 Spindle output (continuous rating/S6-15%) : 53N.m/106N.m

12000r/min  
 direct spindle (BBT40)



### Vertical machining center

High precision & high productivity machining

**Torque: 125N.m (S3/S6/15%, low speed area)**

20000r/min electric spindle (HSK A63)

DT-50、DT-55、spindle **Option**

When the machine tool is cutting at high speed and power, the large torque provided can ensure high-precision processing and excellent surface finish.

T40240MOS-15A electric spindle power/torque pictures

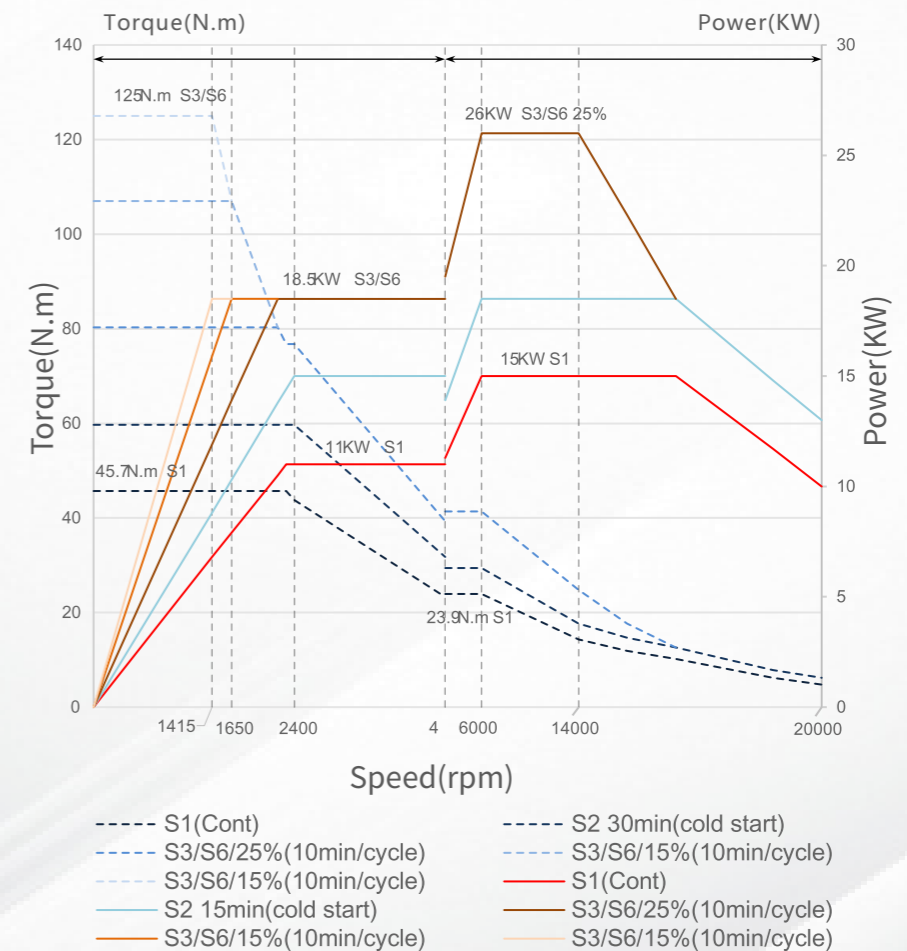

### DT-50, DT-55, standard spindle

The direct 12,000rpm spindle uses a BBT40 tool handle, which has strong cutting rigidity and stable processing accuracy. The spindle uses ceramic bearings and is equipped with a cooling system, which can quickly bring a large amount of heat to the spindle during high-speed cutting, ensuring parts processing accuracy and stability.

Direct 12000rpm spindle power/torque picture

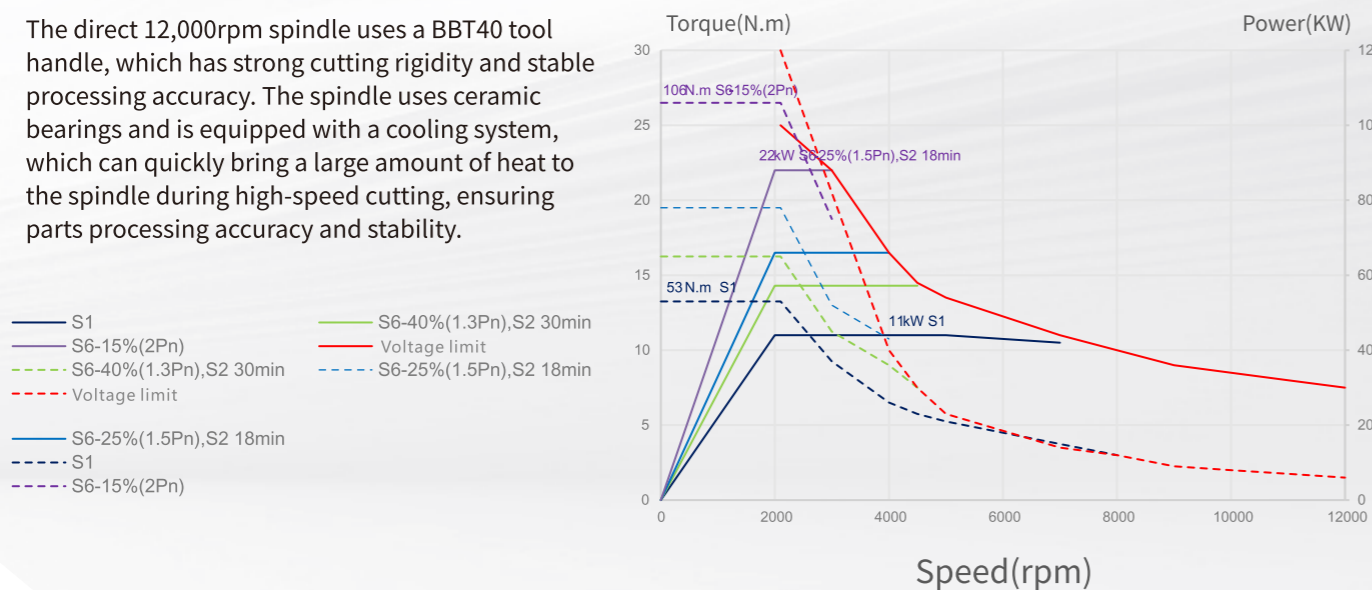

## Vertical machining center

### Superior configuration

### #40 taper tool magazine

DT-50/DT-55/DT-65 DT standard configuration

Standard disc type 30pcs tool, 40pc tool magazine is optional

Changing time (tool to tool, included loosening clamping time)

**1.2S**



		DT-50/DT-55
Tool type	/	BBT40
Tool magazine capacity	pcs	30
Mas diameter (full/vacant in )	mm	80/150
Max length	mm	350
Max weight	kg	8

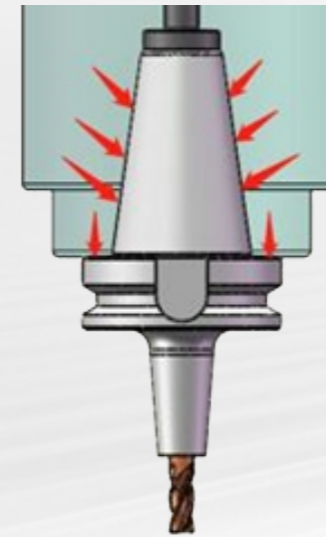

### BBTtool holder DT standard configuration

The spindle is upgraded to the BBT double-sided positioning spindle system to achieve simultaneous double-sided positioning of the spindle cone surface and spindle end surface.

#### Technical advantage

- 1 Improve processing accuracy of surface and size
- 2 The Z-direction size is more stable during high-speed rotation
- 3 Extend tool life
- 4 Improve the repeated accuracy of ATC
- 5 Control micro-wear of taper shank caused by vibration during heavy cutting
- 6 Improve machining roundness for the boring

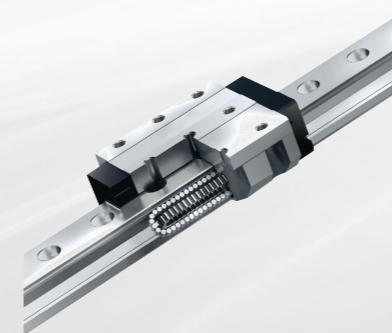

### High Rigidity Roller Guide

DT-50/55 DT standard configuration

- 1 X/Y/Z axis all use imported roller guides to achieve low friction, low vibration, and high rigidity.
- 2 The load capacity is stronger, ensuring the machine's high precision and high speed on the basis of high rigidity.



### Grease lubrication DT standard configuration

- 1 Grease lubrication has a higher load-carrying capacity and better damping and shock-absorbing capabilities than lubricating oils of comparable viscosity.
- 2 Grease lubrication can form a grease ring with a certain sealing effect, which can prevent the intrusion of solid or fluid contaminants and is beneficial for use in humid and dusty environments.
- 3 Due to the absorption effect of the thickener structure system, the grease lubrication has a low evaporation rate, which can greatly save the demand for oil, reduce oil pollution to machine tools and the environment, and is conducive to environmental protection and green environmental protection.

## Vertical machining center

Superior configuration (More options to improve the processing performance)

### Tool checking instrument

Use tool detector can improve processing accuracy, stability, efficiency, safety, reduce costs, and increase the degree of automation. Optional contact and laser tool checking instrument.

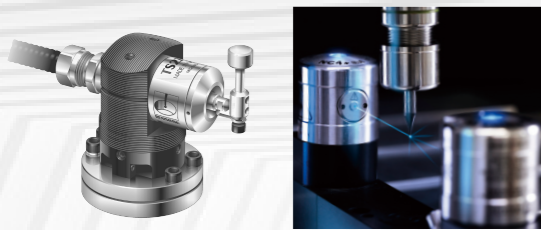

### Grating ruler

Ensuring the processes with high precision and efficiency and stability. It is especially suitable for high-precision processing fields.



### Oil mist collector

It can efficiently collect and purify oil mist generated by processing, effectively improving product quality and safe production working environment.



### Chip removal machine

1.The chip removal machine can quickly and effectively clean chip, avoid the manual cleaning, reduce labor costs, improve production efficiency, and save energy.  
2.Depending on the type of chip removal, chain plate chip removal, scraper type chip removal and compound chip removal machine are optional.

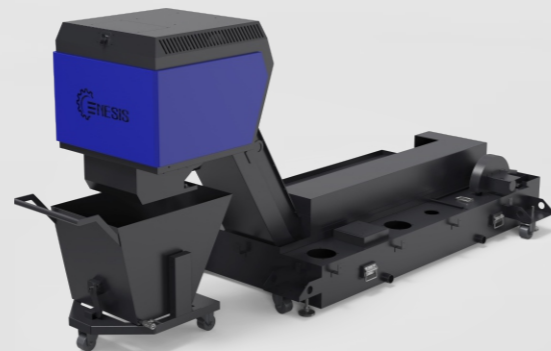

## Vertical machining center

Saving energy & protecting environment  
(Strive to reduce energy consumption and contribute to environmental protection)

### 1 Hollow screw

By delivering a temperature-controlled medium to the center of screw in order to suppressed the generation of heat,thus extend the life and accuracy of the screw. The processing accuracy errors caused by cold and heat will be greatly reduced!

Reduce time costs and energy consumption costs caused by heat!

### 2 Hydraulic tool loosening

By using hydraulic tooling loosening instead of booster tool loosening, the efficiency is more than doubled and the total gas can be saved by more than 55%!

Improve production efficiency and reduce air source loss!

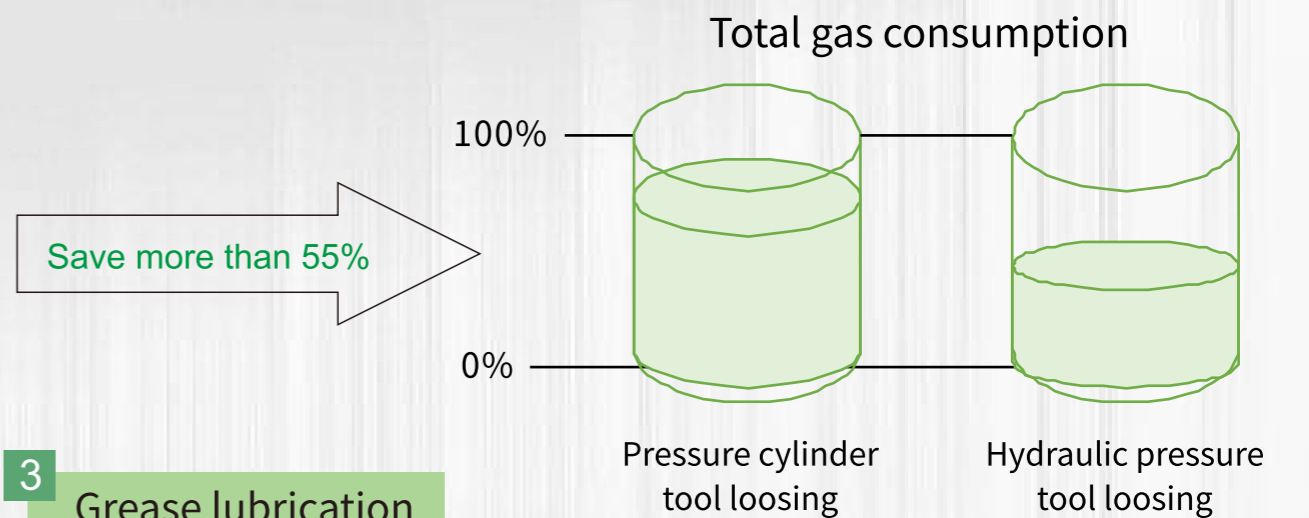

### 3 Grease lubrication



Long greasing cycle,small consumption,low cost



High viscosity & strong adhesion



Prevent pollution from product or cutting fluid  
Green and environmental protection!

## Overall size

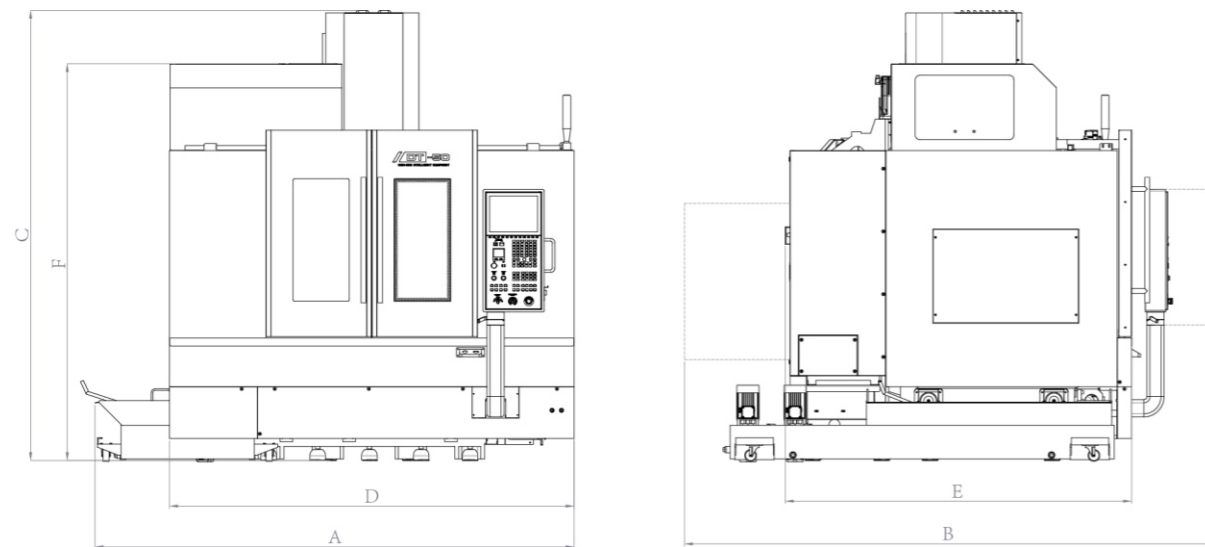

Overall dimension						
Model	Size	A	B	C	D	F
DT-50 standard configuration		3056	3383	2869	2580	2529
DT-55 standard configuration		3176	3418	2904	2700	2544
DT-50 standard configuration (roller scraper type chip removal)		3116	3509	3867	2580	2529
DT-55 standard configuration (roller scraper type chip removal)		3236	3542	2904	2700	2544

## Technical specification

		DT-50	DT-55
X/Y/Z axis stroke	mm	850/500/500	1050/550/550
Distance from spindle nose to worktable	mm	150-650	120-670
Worktable size	mm	1100*450	1200*500
Number of T-slot worktable & size	mm	3-18*125	5-18*100
Max load of worktable	kg	600	800
Spindle speed	rpm	12000 (direct connection)	12000 (direct connection)
Spindle taper	#	BBT40	BBT40
Spindle power (rated/short-time)	kw	11/22	11/22
Spindle torque (rated/short-time)	N·m	53/106	53/106
Tool magazine capacity	pcs	30	30
Max diameter (full/empty neighbour)	mm	Φ80/Φ150	Φ80/Φ150
Max length of tool	mm	350	350
Max weight of tool	kg	8	8
X/Y/Z axis movement speed	m/min	48/48/48	48/48/48

All pictures and parameter configurations in this album are for reference only. The products delivered shall prevail. Our products are being constantly upgraded, and the above information is subject to change without prior notice.

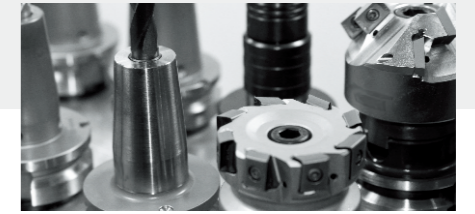

## Configuration

	DT-50	DT-55
BBT30 electric spindle 15000rpm	△	△
BBT30 electric spindle 24000rpm	△	△
BBT40 direct connected spindle 12000rpm	●	●
BBT40 electric spindle 15000rpm	○	○
HSK-A63 electric spindle 20000rpm	○	○
BT50 direct connected spindle 8000rpm	△	△
HSK-A100 electric spindle 10000rpm	△	△
Genesis system	●	●
Mitsubishi system M80A	○	○
Fanuc system Oi-MF/Plus(1)	○	○
Fanuc system Oi-MF/Plus(3)	○	○
Spindle water cooling	●	●
Spindle water outlet system 3/7MPa	○	○
26T arm clamping type tool magazine	△	△
BT40-30T arm type tool magazine	●	●
HSKA63-30T disc type tool magazine	○	○
BT50-24T arm type tool magazine	△	△
BT50-30 arm type tool magazine	△	△
Roller guide rail	●	●
Chain plate type chip removal machine	○	○
Scraper chip removal machine	○	○

● Standard configuration ○ Option ▲ Need consultation △ Not support

	DT-50	DT-55
Cutting fluid cooling system	●	●
Spindle ring water spray	○	○
Explosion-proof light	●	●
Water gun	○	○
Warning light	●	●
Electric box air	○	○
Conditioning system	●	●
Hollow screw cooling system	●	●
Quench worktable	●	●
Double spiral chip removal	●	●
Machine-self chip removal system	○	○
Electric oil-water separator	○	○
Automated door	●	●
Safety door	○	○
Oil mist recovery device	○	○
Micro-lubrication system	○	○
Automated power-off	○	○
Air leakage detection	○	○
Probe 3-axis grating ruler	○	○
Tool checking instrument	○	○

● Standard configuration ○ Option ▲ Need consultation △ Not support